



SparkKIT Instructions

Thank you for purchasing a kit from SparkKIT. Your support is greatly appreciated.

First of all we would like to go through a few basic precautions.

1. This kit includes small parts which may be a choking hazard to small children.
2. This kit requires soldering, please be very careful around the soldering iron.
3. Some parts may have sharp ends, please be careful with these parts.
4. Although this machine outputs very low current, people with a heart condition should avoid shocks from this machine.
5. This machine produces ozone, please use it in a well ventilated area.
6. This product may damage electronic devices such as tablets, computers, cameras or phones- please keep them away from this machine as much as possible.

We recommend you take the time to check the parts, if any parts are missing please contact us at: sparkit.electrostatics@gmail.com

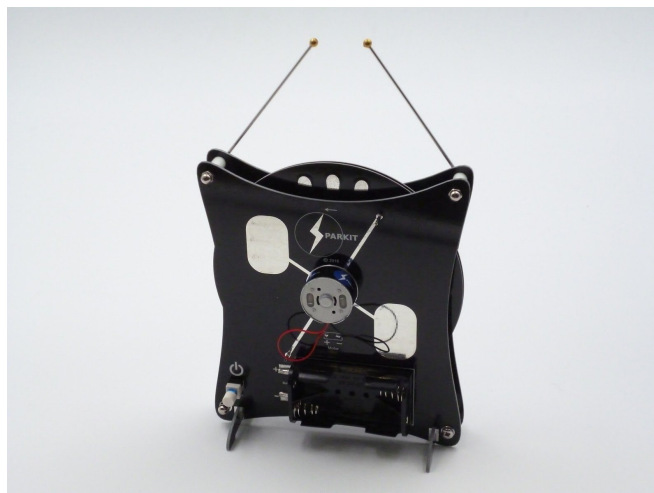

List of Parts:

1. 2 PCB Frame Boards,
2. 2 PCB Disks,
3. 2 Motors,
4. 1 Battery Holder,
5. 2 Stands,
6. 2 Spindles (with white ring),
7. 2 Terminal Rods,
8. 4 Nylon Spacers,
9. 2 25mm Screws With Washers,
10. 2 20mm Screws,
11. 4 Dome Nuts,
12. 7 Small Screws, (1 spare)
13. 2 Plain Washers,
14. 1 Switch,
15. 4 Charge Collectors,
16. 4 Brushes.
17. 1 Cable Tie
18. 1 Alcohol Wipe



Now let's get building, we will explain each step very clearly with pictures, so let's build this thing !

1. For this step you will need to solder the switch, and the battery holder onto one board

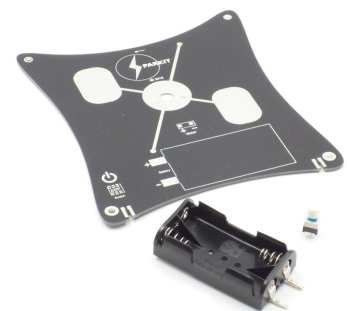

2. Remove the backing paper from the adhesive tape on the underside of the battery holder

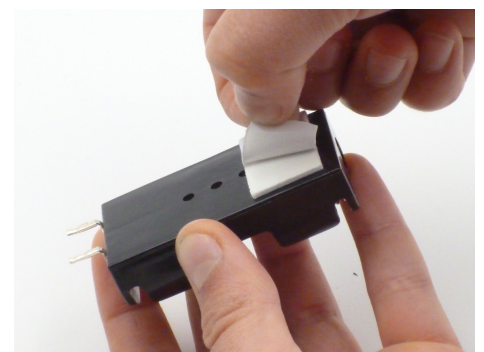

3. Attach the battery holder and solder the connections- take care not to apply too much heat, as this will melt the plastic of the case.

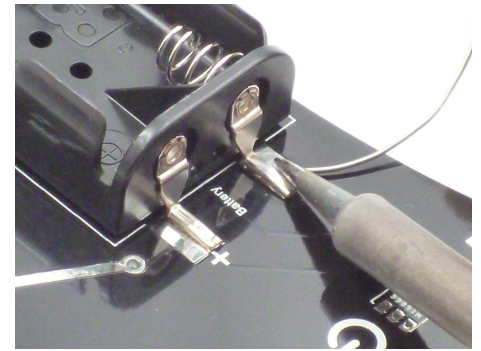
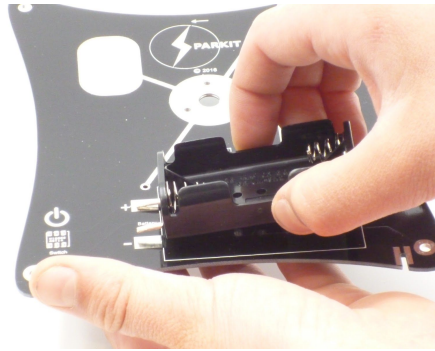

4. Fit the switch into the board.

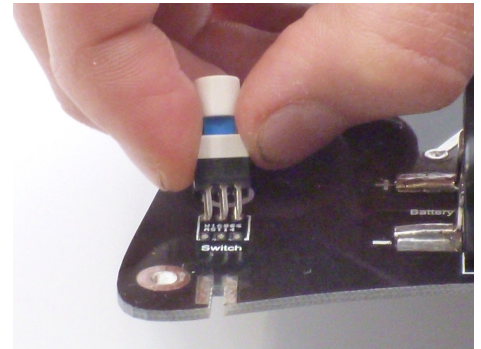

5. Flip the board and carefully solder the switch pins.

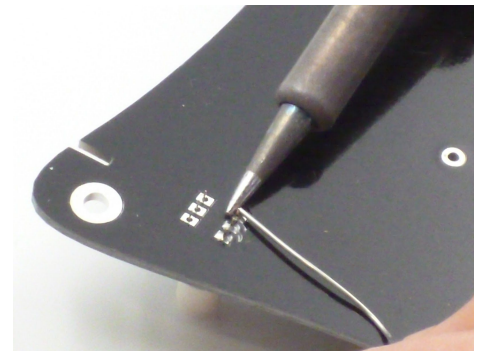

6. Solder two charge collectors onto each board. They need to go on the side that does not have the SparKIT logo. Tweezers are helpful.

HINT- Apply solder to one pad on the board first, then position the charge collector while remelting the solder. Be quick to avoid damaging the board.

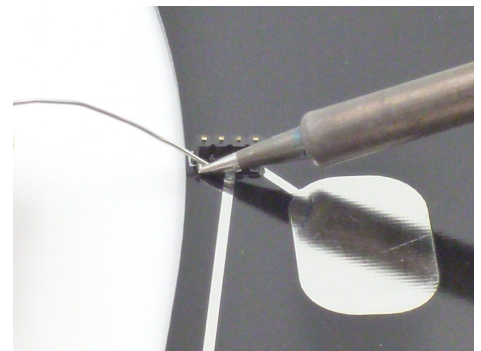

7. The motors should be screwed onto each board with the wires facing down. There are three tiny screws for each motor.

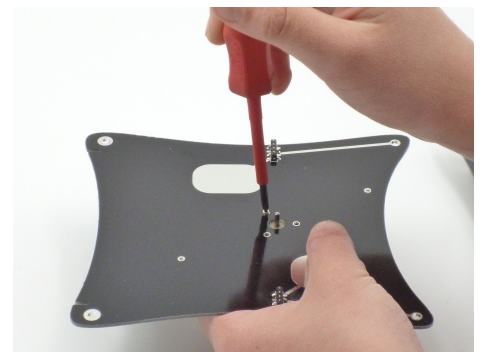
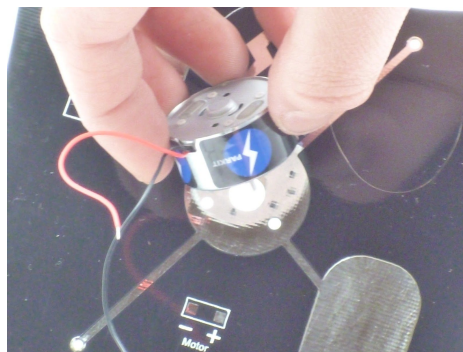

8. Solder the motor wires to their connections as written on board. Red is + black is -

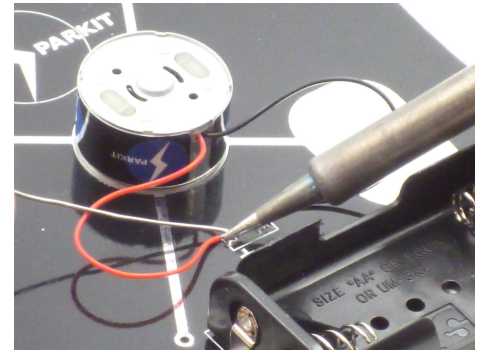

9. Fit and solder 2 brushes to each board, in the holes at the ends of the diagonal tracks. The fibre must be on the same side as the charge collectors. Insert the metal part of the brush, right up to the end the carbon fibre exits, and solder into the hole

WARNING- Do not pull on the fibre !

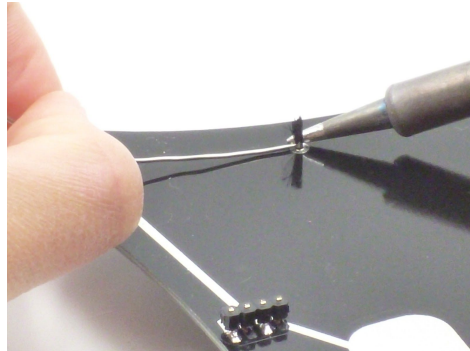
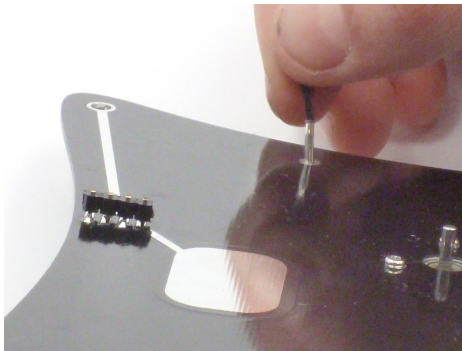

10. You will now need to attach the spindles to the disks

11. Peel the white backing off the spindles to expose the adhesive..

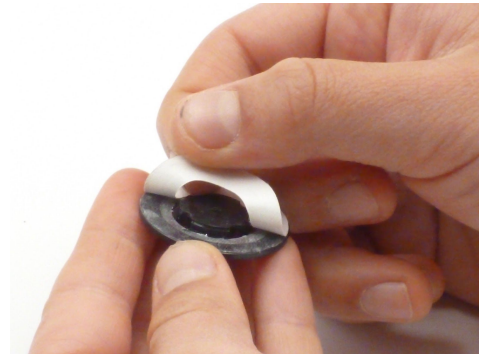

12. The spindles attach to the side of the disk that has the sectors. Push the spindle onto the disk firmly.

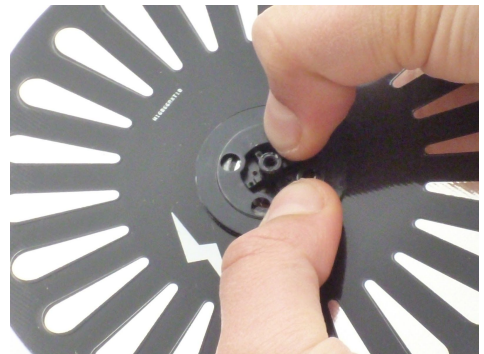
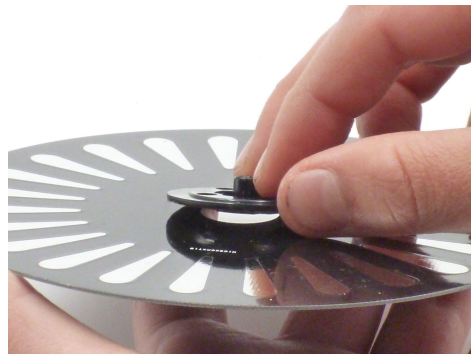

13. At this point you may wish to clean the disks with the alcohol wipe to remove contamination from sweat and skin oil - Wimshurst machines like to be clean and dry.

14. The most difficult part is pushing the spindles onto the motor shaft, and will take a little trial and error. If the spindles are pushed on too far the disks will rub on the charge collectors, if not pushed on far enough the spindles will rub on each other. The cable tie that is included can be used on it's side to set the correct gap of 3.6 millimeters between the spindle and the frame. The handle of a spoon can be used to carefully push the spindle off the motor shaft if it goes on too far.

HINT- a little soap on the motor shaft before fitting the spindles can make this step easier

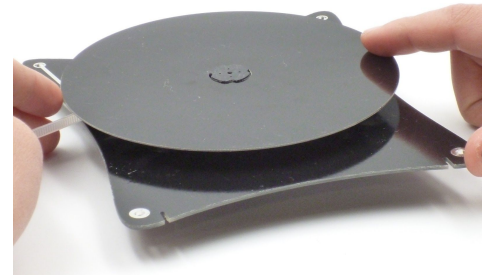

15. Check the fit by temporarily placing the spacers between the boards. **The disks should have only about 1.5 to 2.5 mm of separation, and there should only be a very small gap between the ends of the spindles.** Check there is greater than 0.5 mm between the charge collectors and the disk (a larger gap is fine). **The charge collectors must not contact the disk.**

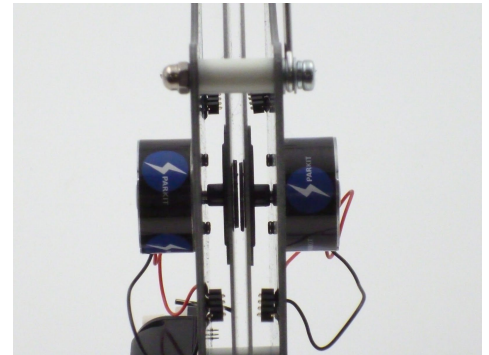

16. Finally the boards can be screwed together. It is easier to fit the screws if the stands are fitted first to hold the boards.

The 25mm screws go at the top with washers and the terminals in the order shown (it doesn't matter which side of the machine the terminals are). The 20mm screws fit at the bottom. The nylon spacers go between the boards.

The order should be:

- screw-head
- terminal rod
- flat washer
- frame board
- spacer
- other frame board
- dome nut

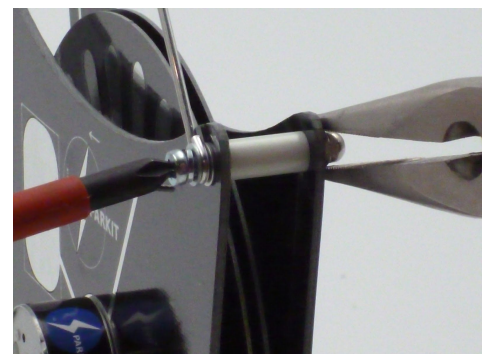
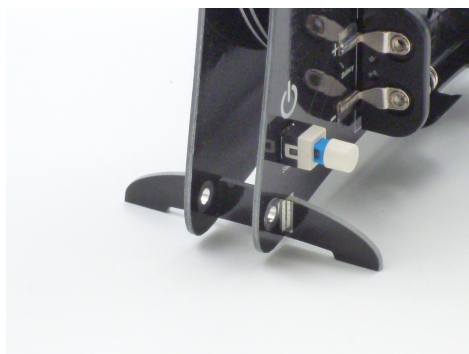

17. You are finished !

Testing and troubleshooting:

Fit 2 AA batteries into the battery holder, set a 5 - 10 mm gap between terminals and switch on. Check rotation direction: There is a small arrow on each board near the top- this indicates correct rotation direction

If the disks rotate, but there is no hissing, sparks or crackle of static electricity, the environment may be too damp. Try drying with a hairdryer. Also check the brushes are in contact with the disks.

The machine will also not start if there is too much gap between the disks, to test this, push on the backs of the motors to bring the disks closer together.

If the disks do not rotate, the spindles may be contacting each other, and should be pushed further onto the motor shafts

If a disk starts to become unstuck from its spindle, which can happen after a hard knock, use an ice-cream stick between the disks to push it back onto the spindle.

A Few Little Experiments

1. Use the machine in the dark, this will help you see the corona discharge. This is a purple glow that comes off certain spots on the machine such as the charge collectors and between sectors.
2. Tape pieces of cotton thread that are about 5 cm long to a terminal rod, and move the terminals apart, before turning on the machine. What happens? We won't tell you, find out for yourself !
3. Cut five to ten 1cm x 1cm pieces of aluminium foil. Move a terminal so that it is sticking out from the machine. Stack the foil pieces on the terminal rod (fold them slightly so they stay balanced). Turn on the machine.
4. Get a popsicle stick and dip the end in saltwater. Hold it between the terminal rods so sparks jump to it. You will see some orange light, this comes from the sodium in the salt.
5. Corona Spinner or ion motor. This is the simplest electric motor ! At high voltage, sharp points leak charge into the air, generating a wind and a hissing noise. A rotor with sharp points facing back can be made to spin when balanced on a terminal. Ground the other terminal by touching it.



6. Spark gap voltage measurement. Use the large curvature of the back of two spoons as a spark gap, it is possible to measure the voltage using this table:

(The large curvature is necessary to create a more uniform electric field that sparks at a consistent voltage. Small spheres concentrate electric fields at their surface creating longer but more inconsistent sparks)

Spark Gap (mm)	Voltage (V)
0.5	2800
1.0	4700
1.5	6400
2.0	8000
2.5	9600
3.0	11200
4.0	14300
5.0	17400
6.0	20400
7.0	23400
8.0	26300
9.0	29200
10.0	32000

There are plenty more fun experiments for you to try by searching the Web

How does it work ?

The Wimshurst machine (invented approx 1880 - 1883 by James Wimshurst) is one of several types of machines generally called 'Induction' or 'Influence' machines. They use the principle of electrostatic induction to repeatedly induce and separate electric charge. This principle is seen in a device called an electrophorus:

- An uncharged conductor on an insulated handle is brought close to a charged object
- Like charge is repelled to the far side of the conductor, and unlike charge is attracted to the close side
- The unwanted charge is removed by briefly grounding the conductor
- The charged conductor can now be removed and it's charge used. Note that no charge has been removed from the first object

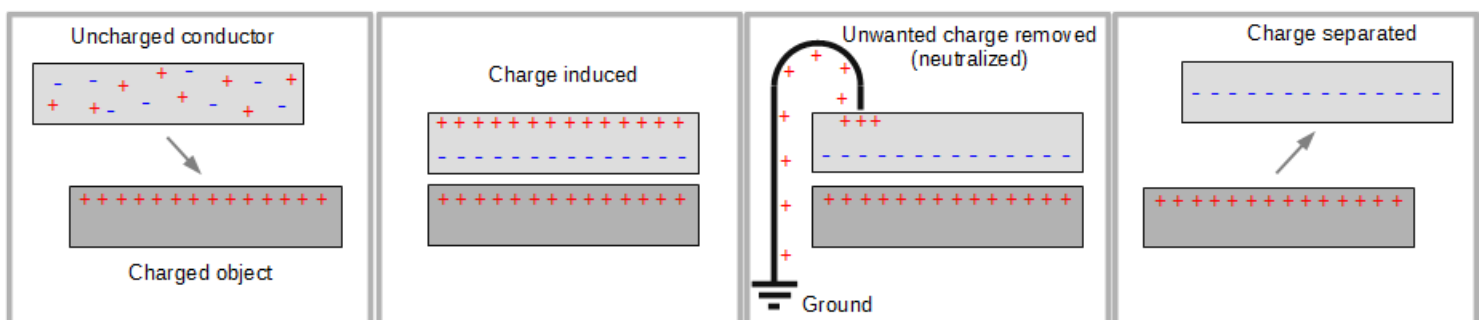

The Wimshurst machine carries out a similar operation automatically when the disks rotate and contact the brushes.

- The sectors on the disk carry charge, and induce charge on the sectors on the other disk
- Unwanted charge is neutralised by the brushes
- Most charge on the sectors is collected by the sharp points on the charge collectors, but some is left to continue the induction process
- The collected charge is stored in capacitors

Traditionally Leyden jars are used for capacitors, but the SparKIT machine has four capacitors built into the circuit board frame. Can you spot them? Can you calculate the capacitance? Stored energy? The board is 1.6mm thick, and has a relative permittivity of 4.4. The plate size is 20 x 30mm with a corner radius of 8mm. The capacitors on each side are connected in series, and then each side in parallel like this:

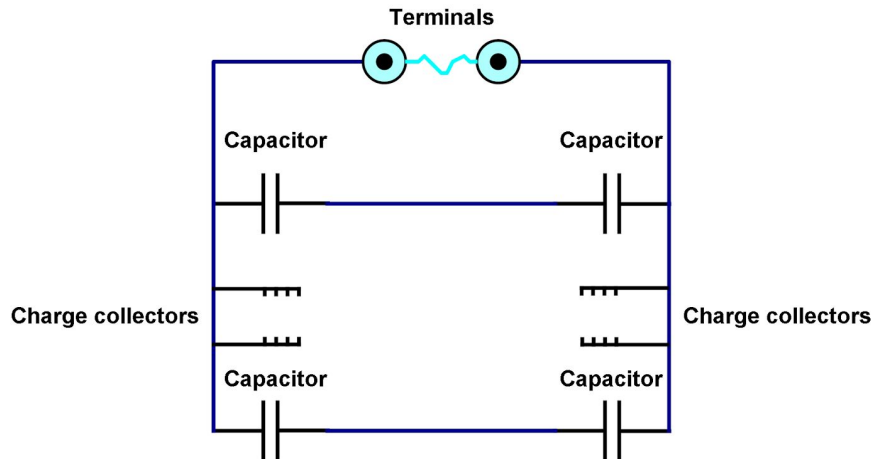

Sometimes the question is asked “what happens if the rotation is reversed” - in this case the charge accumulates at the top and bottom of the disks, instead of the sides.

If you have any questions or comments, please feel free to email them to us at:

sparkit.electrostatics@gmail.com

Or visit our website

www.sparkitelectrostatics.com

**We would also love to see any pictures or experiments you might have done.
If you do send us any, please let us know if we can publish them on the web.**

